

Name _____ Date _____ Partners _____

Polarization

OBJECTIVES

- To study the general phenomena of electromagnetic wave polarization
- To investigate linearly polarized microwaves
- To investigate linearly polarized visible light

OVERVIEW OF POLARIZED ELECTROMAGNETIC WAVES

Electromagnetic waves are time varying electric and magnetic fields that are coupled to each other and that travel through empty space or through insulating materials. The spectrum of electromagnetic waves spans an immense range of frequencies, from near zero to more than 10^{30} Hz. For periodic electromagnetic waves the frequency and the wavelength are related through

$$c = \lambda f, \quad (1)$$

where λ is the wavelength of the wave, f is its frequency, and c is the velocity of light. A section of the electromagnetic spectrum is shown in Fig. 1.

In Investigation 1, we will use waves having a frequency of 1.05×10^{10} Hz (10.5 GHz), corresponding to a wavelength of 2.85 cm. This relegates them to the so-called **microwave** part of the spectrum. In Investigation 2, we will be using visible light, which

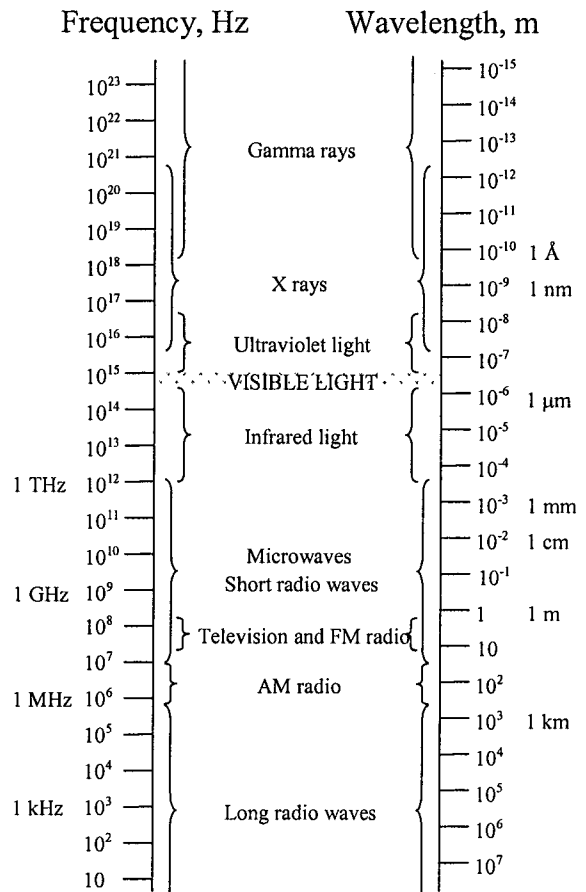

Fig. 1. Section of the electromagnetic spectrum.

has wavelengths of $400 - 700 \text{ nm}$ ($1 \text{ nm} = 10^{-9} \text{ m}$), corresponding to frequencies on the order of $4.3 \times 10^{14} - 7.5 \times 10^{14} \text{ Hz}$. These wavelengths (and hence, frequencies) differ by nearly five orders of magnitude, and yet we shall find that both waves exhibit the effects of **polarization**.

Electromagnetic waves are **transverse**. In other words, the directions of their electric and magnetic fields are perpendicular to the direction in which the wave travels. In addition, the electric and magnetic fields are perpendicular to each other. Fig. 2 shows a periodic electromagnetic wave traveling in the z -direction. Study this figure carefully. We will refer to it often.

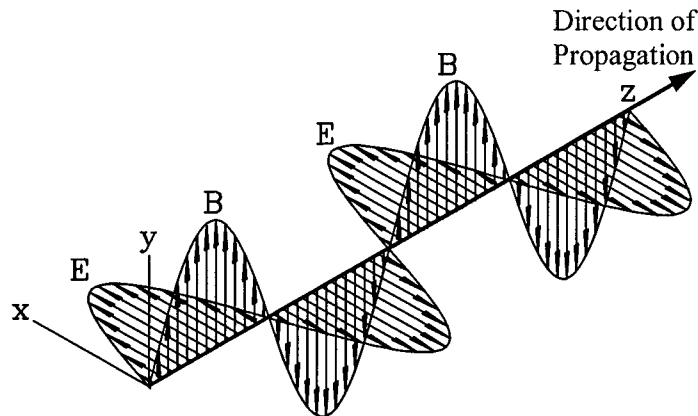

Fig. 2. Periodic electromagnetic wave, \mathbf{E} = vector of the electric field, \mathbf{B} = vector of the magnetic field.

When the electric field of a wave is oriented in a particular direction, that is to say, not in random directions, we say the wave is **polarized**. In this workshop, we will investigate the polarization of two types of electromagnetic waves that have somewhat different wavelengths and frequencies: microwaves and visible light. We will both produce and analyze polarized waves.

Electromagnetic waves are produced whenever electric charges are *accelerated*. This makes it possible to produce electromagnetic waves by letting an alternating current flow through a wire, an **antenna**. The frequency of the waves created in this way equals the frequency of the alternating current. The light emitted by an incandescent light bulb is caused by thermal motion that accelerates the electrons in the hot filament sufficiently to produce visible light. Such thermal electromagnetic wave sources emit a continuum of wavelengths. The sources that we will use today (a microwave generator and a laser), however, are designed to emit a single wavelength.

The inverse effect also happens: if an electromagnetic wave strikes a conductor, its oscillating electric field induces an oscillating electric current of the same frequency in the conductor. This is how the *receiving* antennas of a radios or television sets work. The associated oscillating magnetic field

will also induce currents, but, at the frequencies we will be exploring, this effect is swamped by that of the electric field and so we can safely neglect it.

Even though the electric field vector is constrained to be perpendicular to the direction of propagation, there are still infinitely many orientations possible (illustrated in Fig. 3). Electromagnetic waves from ordinary sources (the sun, a light bulb, a candle, etc.), in addition to having a continuous spectrum, are a mixture of waves with all these possible directions of polarization and, therefore, don't exhibit polarization effects.

Some possible directions of
the electric field vector

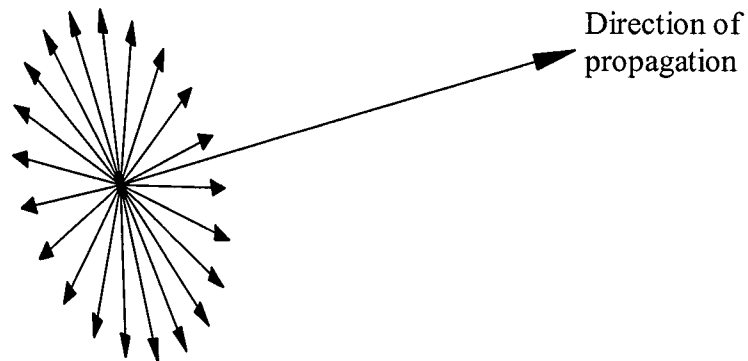

Fig. 3. There are infinitely many possible polarization orientations.

It is, however, possible to produce **linearly polarized electromagnetic waves**. In other words, waves whose electric field vector *only* oscillates in one direction. Look again at Fig. 2. It schematically shows a linearly polarized electromagnetic wave polarized in the x -direction.

The electric field of a plane wave of wavelength λ , propagating in the z -direction and polarized in the x -direction, can be described by:

$$\mathbf{E}_x = \mathbf{i}E_x \sin\left(\frac{2\pi}{\lambda}(z - ct)\right), \quad (2)$$

where \mathbf{E}_x is the vector of the electric field, E_x its amplitude, and \mathbf{i} the unit vector in the x -direction. A wave of the same wavelength, polarized in the y -direction, is described by:

$$\mathbf{E}_y = \mathbf{j}E_y \sin\left(\frac{2\pi}{\lambda}(z - ct) + \phi\right). \quad (3)$$

Here, \mathbf{j} is the unit vector in the y -direction and ϕ is a constant that accounts for the possibility that the two waves might not have the same phase. From two such waves, one can construct all plane waves of wavelength λ traveling in the z -direction.

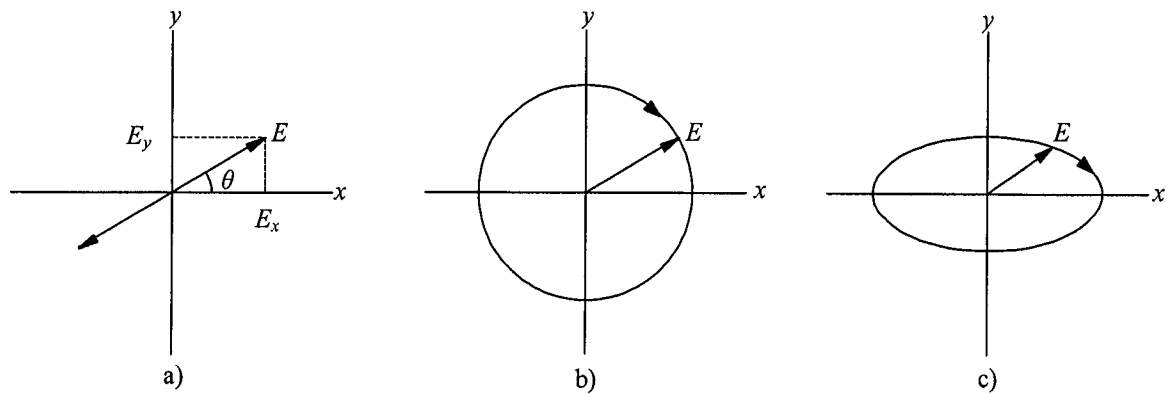

Fig. 4. a) Linear, b) circular, c) elliptical polarization.

If both x - and y -components are present and their phase difference is zero (or 180°), the wave will be linearly polarized in a direction somewhere between the x -direction and the y -direction, depending on the relative magnitudes of \mathbf{E}_x and \mathbf{E}_y (see Fig. 4a). Mathematically such a wave is described by:

$$\mathbf{E} = \mathbf{E}_x + \mathbf{E}_y = (i\mathbf{E}_x \pm \mathbf{j}E_y) \sin\left(\frac{2\pi}{\lambda}(z - ct)\right), \quad (4)$$

where the plus sign refers to a phase difference of zero and the minus sign to one of 180° (π radians). The angle θ between this polarization direction and the x -direction is given by

$$\tan\theta = \frac{E_y}{E_x}. \quad (5)$$

If the phase shift is not zero (or 180°), the wave will not be linearly polarized. While we will only be investigating linear polarization in this lab, it is useful to know something about other types of polarization. Consider the case where the magnitudes are equal, but the phase shift is $\pm 90^\circ$ ($\pm \pi/2$ radians). In other words:

$$E_x = E_y \text{ and } \phi = \pm \frac{\pi}{2}, \quad (6)$$

The resulting wave, called a *circularly polarized wave*, can be written:

$$\mathbf{E} = \mathbf{E}_x + \mathbf{E}_y = E \left[\mathbf{i} \sin\left(\frac{2\pi}{\lambda}(z - ct)\right) \pm \mathbf{j} \cos\left(\frac{2\pi}{\lambda}(z - ct)\right) \right] \quad (7)$$

by making use of the fact that $\sin(\alpha + \pi/2) = \pm \cos \alpha$. With the plus sign, this equation describes a wave whose electric field vector, \mathbf{E} , rotates clockwise in the x - y plane if the wave is coming toward the observer. Such a wave, illustrated by Fig. 4b, is called a *right circularly polarized wave*. With the minus sign, the equation describes a *left circularly polarized wave*.

With the phase shift still $\pm 90^\circ$, but with different magnitudes

$$E_x \neq E_y \quad \text{and} \quad \phi = \pm \frac{\pi}{2}, \quad (8)$$

the \mathbf{E} vector will still rotate clockwise or counterclockwise but will trace out an ellipse as shown Fig. 4c. If there are many component waves of different E_x , E_y , and ϕ , the resulting wave will be unpolarized.

Polarized electromagnetic waves can be obtained in two ways:

1. by using sources, such as certain lasers, that produce only waves with one plane of polarization, or
2. by polarizing unpolarized waves by passing them through a **polarizer**, a device that will let only waves of one particular plane of polarization pass through.

Some sources of electromagnetic waves generate linearly polarized waves. Examples include the microwave generator we'll use today as well as some types of lasers. Other sources generate unpolarized waves. Examples include thermal sources such as the sun and incandescent lamps.

One way of producing linearly polarized electromagnetic waves from unpolarized sources is to make use of a process that directs waves of a given polarization in a different direction than waves polarized in a perpendicular direction. Earlier we noted that the electric field of an electromagnetic wave incident upon a wire induces an oscillating current in the wire. Some energy will be lost through ohmic heating, but more will be re-radiated (scattered). Only the component of the oscillating electric field that is parallel to the wire will induce a current and be scattered. The electric field component perpendicular to the wires, on the other hand, will be essentially unaffected by the wires (assuming a negligible wire diameter). Hence, both the scattered and unscattered electromagnetic waves are linearly polarized.

For microwaves, we can (and will) use an array of actual wires. For visible light, we use a **Polaroid** filter. **Polaroid** filters are made by absorbing iodine (a conductive material) into stretched sheets of polyvinyl alcohol (a plastic material), creating, in effect, an oriented assembly of microscopic "wires". In a Polaroid filter the component polarized parallel to the direction of stretching is absorbed over 100 times more strongly than the perpendicular component. The light emerging from such a filter is better than 99% linearly polarized.

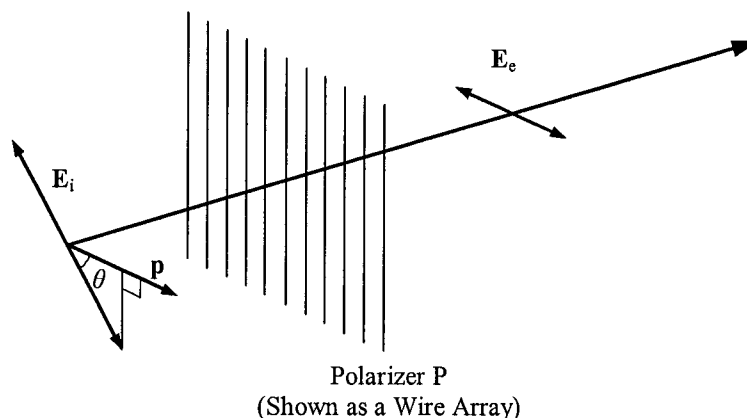

Fig. 5. Effect of polarizer on initially polarized waves.

A polarizer will only pass the components of an electromagnetic wave that are parallel to its polarizing axis. Figure 5 shows polarized electromagnetic waves incident on a polarizing filter, P.

The electric field of the incident wave (\mathbf{E}_i) is oriented at an angle θ relative to the polarization axes of P. Let \mathbf{p} be a unit vector along the polarization axis of the polarizer. The effect of the polarizer, then, is to "project out" the component of \mathbf{E}_i that is along \mathbf{p} : $\mathbf{E}_e = \mathbf{p}(\mathbf{p} \cdot \mathbf{E}_i) = E_i \cos \theta \mathbf{p}$. Because the intensity of an electromagnetic wave is proportional to the square of its electric field amplitude, it follows that the intensity of the electromagnetic waves exiting the analyzer is given by:

$$I_e = I_i \cos^2 \theta. \quad (9)$$

This is known as Malus' Law, after the French physicist who discovered the polarizability of light.

Initially unpolarized electromagnetic waves can be thought of as a mixture of all possible polarizations. Each possible polarization will be attenuated according to Malus' law, and so the total intensity will be the initial intensity times the average of $\cos^2 \theta$ ($1/2$). In other words, the intensity is reduced to one half of the incident intensity.

Except in the case where θ is zero (or 180°), \mathbf{E}_e (the electric field of the electromagnetic waves exiting the polarizer) will have a component that is perpendicular to \mathbf{E}_i . If we place yet another polarizer after P (call it P') with its polarization axis right angles to incident wave's polarization axis, we will get electromagnetic waves out whose polarization is orthogonal to the incident waves' polarization. We have effectively rotated the polarization of the incident waves (with some loss of intensity). Applying Malus' Law, we get:

$$I' = I_i \cos^2 \theta \cos^2 \theta'$$

where θ is the angle between the initial polarization and the first polarizer,

P , and θ' is the angle between P and the second polarizer, P' . But P' is at right angles to the initial wave's polarization, so $\theta + \theta' = 90^\circ$. Hence, $\cos^2 \theta' = \sin^2 \theta$. Using another trigonometric identity ($\sin 2\theta = 2 \sin \theta \cos \theta$), we finally get $I' = 0.25I_i \sin^2 2\theta$. We can see we get the maximum transmission when $\theta = 45^\circ$ ($\sin 2 \times 45^\circ = 1$) and that it is one quarter of the intensity of the incident polarized waves (I_i).

INVESTIGATION 1: MICROWAVE POLARIZATION

For this experiment, you will need the following:

- Gunn diode microwave transmitter
- Microwave receiver
- Wire grid polarizer

CAUTION: DO NOT ALLOW THE RECEIVER'S METER TO PEG AT ANY TIME!

To *peg* the meter means to allow the needle to go beyond the maximum value on the scale. If you find the meter pegged, **immediately turn down the sensitivity and/or move the receiver away from the microwave generator!**

Activity 1-1: Polarization of Microwaves from a Gunn Diode

1. Inside the microwave generator is a solid state device called a **Gunn diode**. When a DC voltage is applied to a Gunn diode, current flows through it in bursts at regular intervals. For your diode, these bursts come at 9.52×10^{-11} seconds apart causing, in addition to the dc current, an ac current at 1.05×10^{10} Hz (10.5 GHz). As a result, a large ac voltage, oscillating at that frequency, is present across the slot, and so a wave is radiated from the horn. The *electric* field of this wave oscillates in the same orientation as the Gunn diode. The **polarization** of an electromagnetic wave is determined by the direction of the *electric* vector \mathbf{E} . The *magnetic field* \mathbf{B} encircles the current in the Gunn diode and so emanates in the orientation *perpendicular* to \mathbf{E} .

Important Note: The Gunn diode is placed inside the generator in a way that the electric field will oscillate vertically when the knob on the back is placed at 0° .

2. Just inside the horn of the receiver is a microwave detector. In addition, there is some circuitry, which amplifies the signals received by the detector and outputs this amplified signal to a d'Arsonval meter and to an external output. The amplification, or alternatively its inverse, the sensitivity, (also labeled METER MULTIPLIER), is controlled via two

knobs. The VARIABLE SENSITIVITY knob allows for fine adjustment. As you turn *up* the sensitivity (from 30 to 1), the signal is amplified more and more.

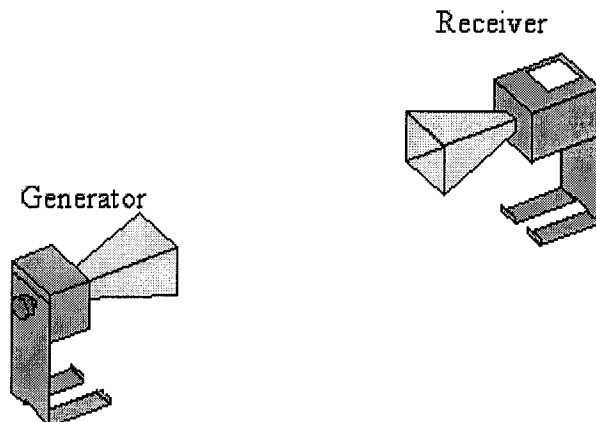

Fig. 6. Use this arrangement to test for polarization.

3. Set up the generator and receiver as shown in Fig. 6, with about 75 cm between the faces of the horns.

Prediction 1-1: With what relative orientation of the transmitter and receiver do you expect to find minimum intensity? What does this tell you about the electromagnetic microwaves?

4. Set the knobs on back of both pieces so the angle indicator is at 0° . Adjust the sensitivity on the receiver to obtain a signal near 0.5 on the meter. If you cannot achieve this with a sensitivity of 10 or 3, move the receiver closer to the generator. Rotate the *receiver* and verify that it is sensitive to the polarization of the wave. Return the receiver angle to 0° .

Question 1-1: Does it make sense that maximum intensity is obtained when both generator and receiver are oriented the same way? Explain why. Why does the received signal go to zero when they are at 90° with respect to one another?

Activity 1-2: Wire Grid Polarizer

Prediction 1-2: With the generator and receiver oriented the same way, what orientation (relative to the generator) of a wire grid placed in between them will give the maximum received intensity?

Prediction 1-3: With the generator and receiver oriented at 90° with respect to one another, what orientation (relative to the generator) of a wire grid placed in between them will give the maximum received intensity?

1. Make sure that the generator and the receiver are oriented the same way: with the **E** field horizontal (indicators at $\pm 90^\circ$).
2. Insert the wire grid polarizer between the generator and the receiver so that the wires are initially oriented horizontally (parallel to the direction of the **E** field). Slowly rotate the polarizer so that the wires become perpendicular to the **E** field.

Question 1-2: With what relative orientation(s) of the polarizer did the receiver indicate the highest intensity? The lowest?

3. Rotate the receiver's angle by 90° so that the generator and receiver are orthogonal and turn up the sensitivity to 1.

4. Repeat step 2.

Question 1-3: With what orientation(s) of the polarizer did the receiver indicate the highest intensity? The lowest?

INVESTIGATION 2: POLARIZATION OF A HIGH-INTENSITY LAMP

NOTE: IN THE REMAINDER OF THE WORKSHOP WE WILL INVESTIGATE THE POLARIZATION OF VISIBLE LIGHT. FOR THE NEXT THREE INVESTIGATIONS, IT WILL BE NECESSARY TO TURN OFF ALL OF THE LIGHTS IN THE LAB TO OBTAIN THE BEST RESULTS.

In this investigation, the unpolarized light from a high-intensity lamp will be linearly polarized. This polarization will be investigated with a second Polaroid analyzer. In addition, a third polarizer will be added to investigate the effect of the orientation of a third polarizer on the intensity.

For this you will need the following:

- Optical bench with lens holders
- Polarizer
- Bausch and Lomb polarized light demonstrator kit
- Small support stand
- Desk lamp (high intensity light source)
- Light sensor and cable

Activity 2-1: Linearly Polarized Light and Malus' law

Note: The light sensor that will be used for the rest of the experiments is a photodiode with a sensitivity that ranges from 320 nm to 1100 nm. **Make sure not to allow the output voltage from the sensor to go above 4.75 volts. At this point, the sensor is saturated and you will not get accurate readings.**

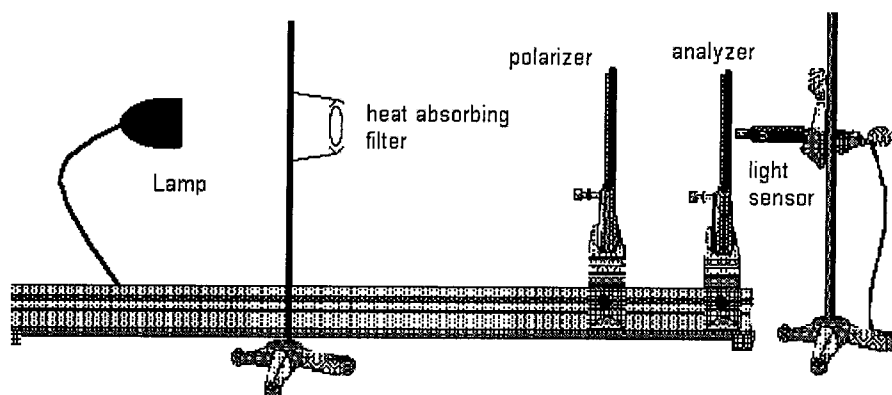

Fig. 7. Setup of the linearly polarized light experiment.

1. Set up the lamp, polarizers, and light sensor as shown in Fig. 7. **DO NOT TURN YOUR LAMP ON YET.** Make sure your lamp is on the opposite end of the table from the computer and is pointing towards the wall, not towards the center of the room. We want to minimize the interference of the light coming from the desk lamp into each other's light sensor.
2. The heat-absorbing filter (item #1 in the box of components) should be mounted on the small support stand in between the light source and the first polarizer.
3. Ensure that the heights of the light, heat absorbing filter, polarizers and light sensor are lined up. Your lamp can now be turned on.

ALWAYS PLACE THE HEAT ABSORBING FILTER BETWEEN THE LIGHT AND THE FIRST POLAROID FILTER TO BLOCK THE INFRARED LIGHT AND PREVENT HEAT DAMAGE

Note: The infrared light emitted from the lamp will not be polarized by the filters, but will be seen by the photodetector.

4. Connect the light sensor to channel A in the PASCO interface.
5. Open the experiment file named **Linearly Polarized**. There should be a data table when you open the file.
6. In the data table, the first column will be the values for **angle** that you enter. The second column is **Light Intensity**. This column shows the

percentage of maximum light intensity that is currently being put out by the sensor. The third column is the **voltage** column. The units for intensity are not volts but Lumens. However, the output of the light sensor probe in volts is directly proportional to the light intensity. **Never let the output from the light sensor exceed 4.75 V**

7. Ensure that the light from the lamp is incident on the heat absorbing filter, then travels through the first polarizer, then through the analyzer, and then onto the light sensor.
8. Make sure that the two polarizers are aligned (both at 0°). This is necessary to ensure that the output is not too high.
9. Press **Start** to begin collecting data. The output from the light sensor will be shown in the digits window and in the third column of the first row. A typical voltage reading when the lamp and sensor are 50-60 cm apart is in the range of 0.5 to 1 V. There is a sensitivity switch on the light sensor that you may need to adjust.

10. Set the first polarizer to 0° and the analyzer to -90° (counterclockwise value; see Fig. 8 for a possible convention). *The Polaroid Filters we are using allow the electric field E vector of the transmitted light to oscillate in the direction of the indicator tab on the Polaroid.*

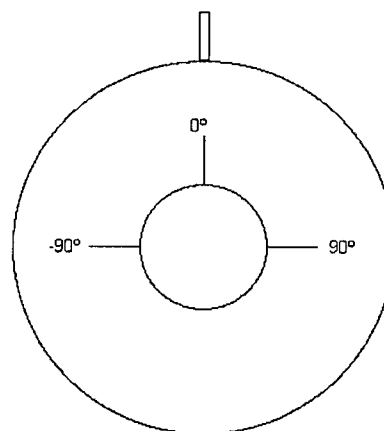

Fig. 8. Convention for measuring angle of polarizer. This diagram is noted while looking toward the light sensor, along the path of the light.

11. When you feel that the reading has stabilized, press **Keep**. A box will pop up that asks you the angle of the polarizer. Type in “-90” and press Enter.
12. Adjust the analyzer to an angle of -80° . The voltage output will now be shown as before. Press **Keep** and type in the angle.
13. Adjust the angle of the analyzer in 10° steps from -90° to 90° . Repeat step 11 until all of the values are entered, putting in the respective values for the angles. This can go rather quickly with one person changing the angle and another person operating the computer. Once **Keep** has been selected, the next angle can be changed by one group member while another is entering the angle into the computer.

14. When you are finished entering data, click on the red square next to **Keep** to stop data collection.
15. **Print** out your graph table for your report. Only print one per group. You may need to print it twice to include all the data.
16. At the bottom of the screen, there should two graphs minimized. Bring up the graph titled **I vs. Angle** so you can see the graph of your light intensity plotted versus angle. If you see a fit to your data, you have brought up the wrong graph.

Question 2-1: What does your graph look like? Does it follow the curve you would expect?

17. Minimize this graph, and maximize the second graph noted in a box at the bottom titled **Fit Malus**. You will see your data plotted along with a fit. You could have easily entered this fit into Data Studio yourself, but we have done it for you to save time. We have fit intensity I versus $\cos^2 \theta$ using a function of the form $I_2 = I_1 \cos^2 \theta + I_B$. That is, we are using a linear fit of the form, $y = mx + b$.

Question 2-2: What values did you find for the intensities I_1 and I_B ? Enter your values below. What does the value for I_B represent? Explain the results of your equation. What is physically happening?

I_1 _____

I_B _____

Question 2-3: Is it possible that I_B is not constant? Explain. How could you minimize I_B ?

Question 2-4: Does it appear that Malus' Law (Eq. 9) is obeyed? Explain.

18. **Print** out your graph and attach it at the end of your lab. Only print one per group.

Note: The following experiment will use all of the setup from **Activity 2-1**. Leave everything in place.

Activity 2-2: Three Polarizer Experiment

1. Using the setup from **Activity 2-1**, set the two existing polarizers so that they are crossed (e.g. the polarizer at 90° and the analyzer at 0°).

Make sure to leave the heat absorbing filter in place between the lamp and the polarizers!

Prediction 2-1: What is the orientation of the electric field after it passes through the first polarizer? What will happen to this light when it reaches the second polarizer?

Prediction 2-2: With this arrangement, what output do you expect from the light sensor?

Prediction 2-3: A third polarizer will be added in between the other two. What effect will this have, if any, on the output of the light sensor?

Prediction 2-4: What orientation of the third polarizer (in between the first two) do you expect would produce maximum voltage? Give the angle with respect to the first polarizer.

2. Place the third polarizer in between the other two.
3. Open the experiment file named **Three Polarizer**. There should be two digit displays; one for voltage output and one for intensity. Press **Start** to activate the displays.
4. Adjust only the middle polarizer and find the orientation for which the output shown on the computer is a maximum. Record the angle at which the maximum occurs.

Angle _____

5. Click on the red square to stop the data collection.

Question 2-5: Explain your findings in terms of the orientation of the electric field after the light travels through each polarizer. Why would the angle found in step 4 produce the maximum intensity?

INVESTIGATION 3: BREWSTER'S LAW

An alternative way to produce linearly polarized light is based on **Brewster's law**. A wave falling on the interface between two transparent media is, in general, partly transmitted and partly reflected. However, there is a special case in which the directions of the *refracted* and *reflected* waves are perpendicular to each other, as shown in Figure 9.

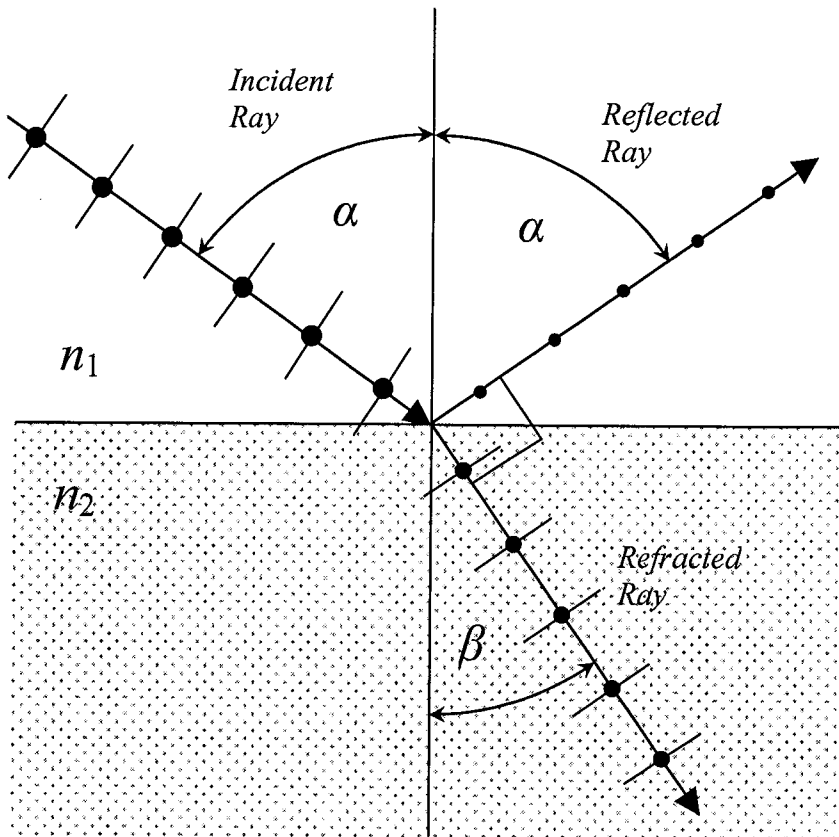

Fig. 9. Reflection at Brewster's angle. The electric field of the p wave (represented by short lines, |) is *in the plane of the paper* while the electric field of the s wave (represented by dots, •) is *perpendicular to the page*.

The component of the wave whose electric field vector \mathbf{E} is *in the plane of the page*, called the **p wave**, is not reflected at all but completely

transmitted when the incident angle is α (called Brewster's angle) from the normal. The electric field of the p wave is represented by the short lines ($|$) in the figure. Meanwhile, the reflected light contains the remainder of the wave, the component whose electric vector oscillates *perpendicular to the plane of the page*. Therefore, the light that is reflected is totally polarized. This second wave is usually called the **s wave**. The electric field of the s wave is represented by the dots (\bullet) in the figure.

The angle of incidence satisfying the condition of Brewster's law, called **Brewster's angle**, is easily obtained from Fig. 9. Noting that

$$\alpha + \beta = \frac{\pi}{2} \quad (10)$$

and using Snell's law ($n_1 \sin \alpha = n_2 \sin \beta$, where n_1 is the index of refraction of the medium containing the incident ray, and n_2 is the index of refraction of the medium containing the refracted ray), we can show:

$$\frac{n_2}{n_1} = \frac{\sin \alpha}{\sin \beta} = \frac{\sin \alpha}{\sin\left(\frac{\pi}{2} - \alpha\right)} = \frac{\sin \alpha}{\cos \alpha} = \tan \alpha. \quad (11)$$

In the case that you will be looking at in class, the index of refraction of the first medium, n_1 is equal to the index of refraction of air. For this workshop, this will be taken to be unity. Putting this into Eq. (11), we get:

$$n = \tan \alpha \quad (12)$$

where n is the index of refraction of the glass plate.

Brewster's law is just a special case of the **Fresnel equations** that give the amplitudes of the transmitted and reflected waves for all angles for the two polarizations.

The polarization upon reflection is rarely used to produce polarized light since only a few percent of the incident light are reflected by transparent surfaces and become polarized (metal surfaces do not polarize light on reflection). But the fact that light reflected by glass, water, or plastic surfaces is largely polarized enables one to cut down *glare* with Polaroid glasses or Polaroid photographic filters.

If one shines light at the Brewster angle onto a plane parallel glass plate, as shown in Fig. 10, the Brewster condition is satisfied at both the entrance and the exit face. This means that the p wave is perfectly transmitted (without reflection) by both surfaces. Such an arrangement is called a **Brewster window**.

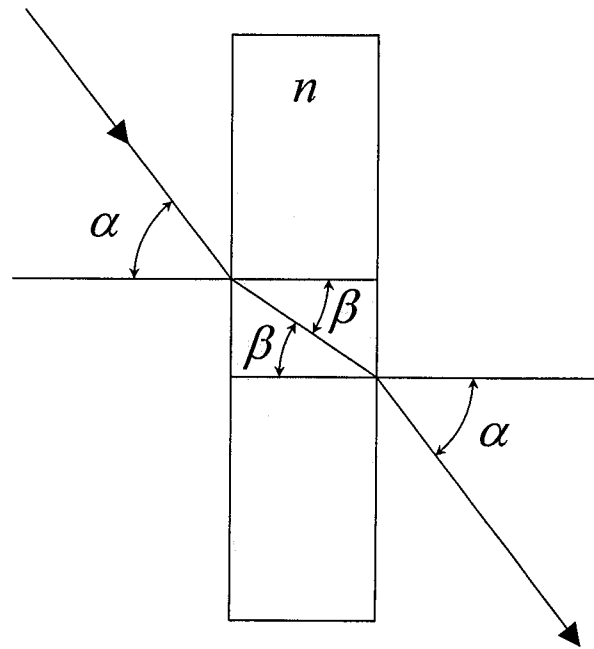

Fig. 10. Brewster window.

Brewster windows are often used in gas lasers as shown in Fig. 11. The p wave will be completely transmitted by both windows, enabling the external reflectors to establish the standing wave necessary for laser operation.

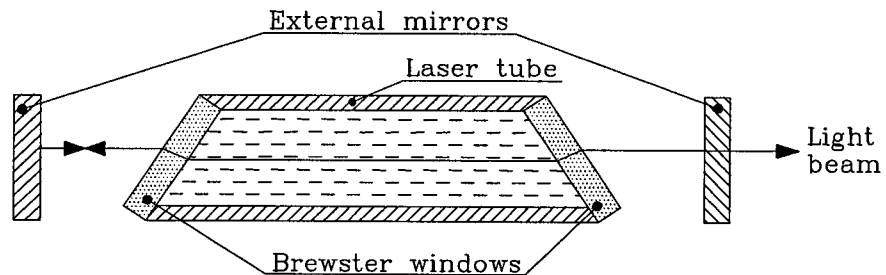

Fig. 11. Brewster windows in a gas laser.

The component whose electric vector is perpendicular to the plane of the figure (the s wave) is partially reflected by the Brewster windows so that a standing wave of sufficient intensity for laser operation cannot be established with this polarization. Lasers of this kind produce light that is plane-polarized in the plane of the paper. Gas lasers whose reflectors are inside the tube can oscillate simultaneously in both polarization modes and will produce unpolarized light.

In this investigation, a laser will be used to test Brewster's Law.

For this investigation, you will need the following:

- Laser
- Polarizer
- Glass plate taped to mount

- Goniometer [Basically two sticks pinned together and a protractor to measure the angle between them. Today we won't be using the sticks, just the protractor.]
- Small support stand

WARNING: LASER LIGHT CAN DAMAGE THE EYES. NEVER LOOK DIRECTLY INTO THE BEAM OR AT LASER LIGHT REFLECTED FROM METAL, GLASS OR POLISHED SURFACES.

Activity 3-1: Determination of Brewster's Angle

Prediction 3-1: You will be using crown glass as your Brewster window in the following experiment. What angle do you expect to find, knowing the index of refraction of crown glass (see Appendix A)?

1. Place the goniometer on the table next to the middle of the optical bench. Place the mounted glass plate on the goniometer hinge. This will serve as your Brewster window. See Fig. 12.

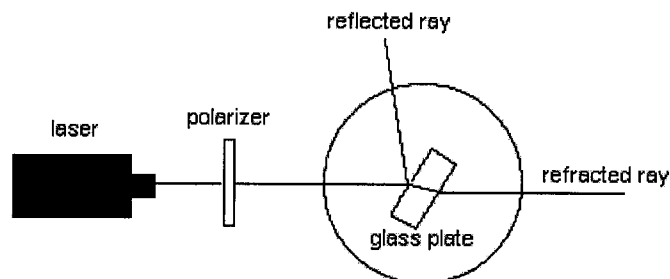

Fig. 12. Diagram looking from above the apparatus. The light from the laser travels through the polarizer and to the glass plate, where some of it is reflected and some is refracted.

2. Adjust the laser so that the beam produced is horizontal and is incident upon the glass plate. The distance between the laser and glass plate should be about 50 cm, but this does not require a measurement.
3. Place a polarizer and holder on the table in between the laser and the glass plate, so the light travels through the polarizer.

Recall that only the s wave (electric field vector \mathbf{E} parallel to the glass plate) is reflected at Brewster's angle (see Fig. 9). If the s wave is not present in the incident light, then the Brewster's angle can be found quite easily; it will be the point at which no light is reflected. We want to use the polarizer to only allow the p wave (electric field vector \mathbf{E} in horizontal plane) to be incident upon the glass plate.

Question 3-1: At what angle should we set the **polarizer** to transmit only the p wave?

Polarizer angle for only p wave transmission: _____

Explain how you decided upon this angle:

Note: Make sure that the polarizer does not completely block the laser light. To check this, look at the glass plate to ensure that there is light incident upon it. Also try to find the refracted beam. No matter what the angle of the glass plate is with respect to the beam, there will always be a refracted (transmitted) beam – the p wave is always refracted.

4. Set the polarizer at the angle you just determined in Question 3-3.
5. You *may* find that your laser is polarized (some of our lasers are, some aren't). If so, you may have to rotate the laser about its axis so that enough of the beam passes through the polarizer to clearly visible.
6. Let the reflected light fall upon a notebook size piece of white paper as a screen to show the reflected ray, rotate the glass plate until you find the position at which the intensity of the reflected light becomes a minimum. You may find that by alternately "tweaking" the polarizer angle and the plate angle, you can make the reflected ray completely vanish.

Note: Be careful to position the laser beam so that it does not miss the glass plate as you rotate the spectrometer stand. **Do not let the laser beam shine into the computer screen or the light sensor.**

7. Read the angle on the goniometer for the position for which the light is a minimum.

θ _____

8. Rotate the glass plate until the beam is reflected back into the laser. Read the angle on the goniometer again and consider this your *zero angle*.

$$\theta_0 \text{ _____}$$

9. Find the value for $|\theta - \theta_0| = \alpha$. This is your **Brewster's Angle**.

$$\alpha \text{ _____}$$

10. Use Equation (12) to determine the index of refraction of the crown glass.

$$n \text{ (index of refraction): _____}$$

Question 3-2: Does your experimental value of the Brewster's angle agree with your **Prediction 3-1**? Compare and explain.

INVESTIGATION 4: OTHER METHODS FOR POLARIZING AND DEPOLARIZING

DEPOLARIZATION

To change polarized light into unpolarized light one must introduce random phase differences between the two components of the electric vector. This can be accomplished by interposing a material that is both inhomogeneous and anisotropic across the wave front.

BIREFRINGENCE

Most of the transparent materials that one encounters daily, such as glass, plastics, and even crystalline materials such as table salt, are optically isotropic, i.e. their index of refraction is the same in all directions. Some materials, however, have an optically favored direction. In these materials the index of refraction depends on the relative orientation of the plane of polarization to that preferred direction. Such materials are called **birefringent** or **doubly refracting**. The best known example of such materials is calcite (CaCO_3). Optically isotropic materials, such as glass, can be given a preferred direction, and thus made to be birefringent, by stressing or bending them.

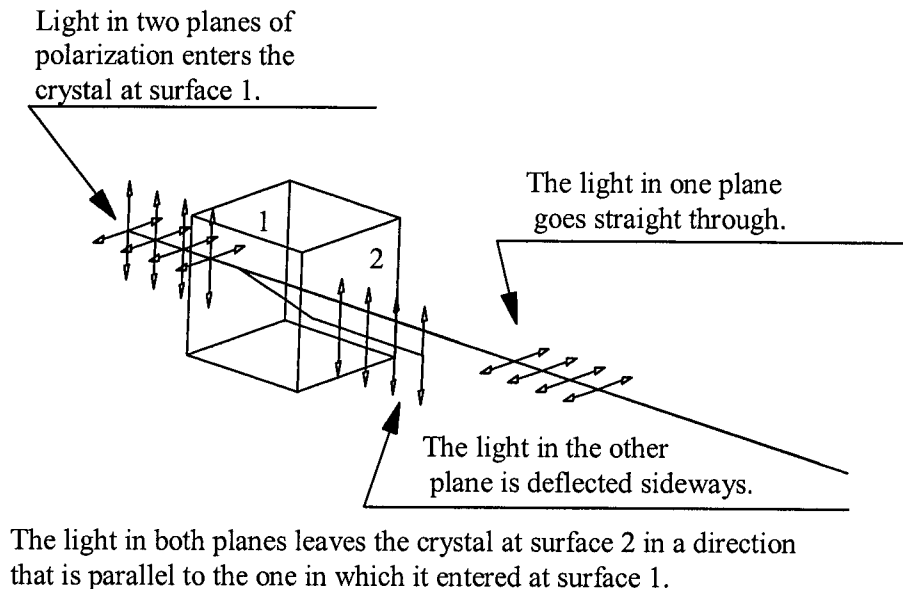

Fig. 13. Light passing through a birefringent crystal.

Consider a light wave traversing a birefringent crystal, as shown in Fig. 13, where the direction of propagation of the wave is entering the crystal perpendicularly. An initially unpolarized light beam will split into two separate linearly polarized beams. One of these is called the **ordinary ray** or **o-ray** and the other the **extraordinary ray** or **e-ray**. The behavior of the o-ray is essentially that of a ray in an isotropic medium: it is refracted in accordance with Snell's law, and its refractive index n_o is independent of the direction of travel. The e-ray, on the other hand, behaves in a most peculiar way. Its index of refraction n_e depends on the orientation of the crystal. Moreover, its direction of travel, after entering the crystal is not consistent with Snell's law. As Fig. 13 shows it will be refracted even if its angle of incidence is 90° . On leaving the crystal it becomes again parallel to the direction of incidence but displaced with respect to the incident beam. Since the two emerging rays are linearly polarized along mutually perpendicular directions doubly refracting crystals make very effective polarizers: If one cuts a birefringent crystal so that the e-ray, but not the o-ray, is totally reflected at the exit face one can produce light that is 99.999% linearly polarized.

Another application of birefringence is the **quarter-wave plate**, a device that can be used to convert linearly into circularly polarized light and vice versa. Consider again Fig. 13: Not only do the e- and the o-rays experience a different coefficient of refraction, but they also travel different distances in the crystal. As a result they will be out of phase with respect to one another. Through a suitable choice of the thickness of the crystal one can arrange it that the phase difference between the two rays becomes a quarter of a wavelength, in which case a linearly polarized incident light beam will be circularly polarized on leaving the crystal.

The wavelength dependence of the index of refraction, although small, lends itself to some pretty demonstration experiments. If one places two Polaroid filters in front of a light source so that their directions of polarization are perpendicular to each other, they will appear dark. If one then places an object made of a birefringent material between the crossed Polaroids, a multicolored image of the object will become visible in the previously dark field. The o-ray and the e-ray have traveled different optical path lengths and their phases, upon leaving the object, will differ, the difference being a function of the wavelength of the light. Since the two rays are polarized in different directions they cannot interfere with each other. The second Polaroid (the analyzer) passes that component of each ray whose plane of polarization is parallel to the direction of polarization of the filter. These components have the same plane of polarization and can interfere. Whether their interference is constructive or destructive will depend on their phase difference and hence on their color.

In this investigation, you will use different objects and materials to both polarize and depolarize light. You will need the following materials:

- Polarized light demonstrator kit
- Optical bench with lens holders
- 2 small support stands with tripod base
- Desk lamp

Activity 4-1: Depolarization

As you will recall from the readings above, random phase differences may be introduced between the two components of the electric field vector to depolarize the light.

1. Set up two polarizers with the desk lamp and heat-absorbing filter as done in **Investigation 2**. Set the first polarizer such that \mathbf{E} is vertical. You will be looking through the two polarizers at the light coming from the desk lamp through the heat-absorbing filter.

Prediction 4-1: With this setup, what do you expect to be the relationship between intensity and angle of the second Polaroid (analyzer) with respect to the first polarizer? (Hint: we did this in **Investigation 2**).

Prediction 4-2: With the wax paper added between the polarizers, do you expect the relationship between intensity and angle to change? Why or why not? What do you expect the new relationship will be, if you think it will change?

Test your prediction:

2. Hold the piece of wax paper from the polarizing kit in between the two polarizers. Look at the light from the desk lamp.
3. Rotate the polarizer through 180° and observe the transmitted light.

Question 4-1: Describe the transmitted light intensity as you rotate the polarizer.

Question 4-2: What does this show you about the polarization of the light through the wax paper?

Activity 4-2: Birefringence by the Calcite Crystal

Set the calcite crystal from the polarization kit on the dot to the right: ●

1. Hold a polarizer over the calcite and look through it at the dot.

Question 4-3: What do you observe and with and without the polarizer?

2. Slowly rotate the polarizer until only one dot is seen. Note the orientation of the polarizer.

θ_1 _____ (choose a relative zero angle)

3. Rotate the polarizer again until the other dot is seen. Note the orientation of the polarizer.

θ_2 _____ (use same zero angle as before)

Question 4-4: What does this tell you about the relative polarization of the images created by the calcite crystal?

Activity 4-3: Interference Caused by Birefringence

1. Hold the mica sample between two crossed polarizers (set at 90° and 0° , for example) and look through the setup at the lamp.

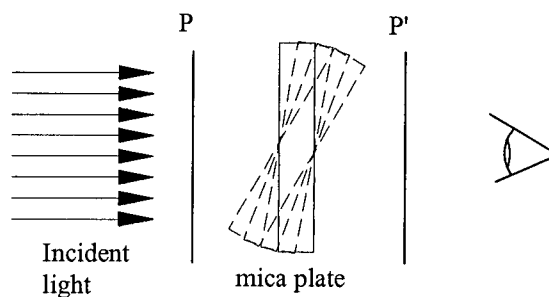

Fig. 14

2. Tilt the mica sample slowly backwards as shown in Fig. 14.

Question 4-5: What do you see?

Question 4-6: Do your observations depend on the angle at which you hold the mica?

Activity 4-4: Birefringence Due to Stress

Replace the mica with the U-shaped piece of plastic between the crossed polarizers.

1. Look through the polarizer at the plastic.

Question 4-7: What do you observe? Do you see light?

Question 4-8: Based on your previous observations, is the light polarized by the plastic? Why or why not?

2. Lightly squeeze the two legs of the U toward each other while looking at the plastic through the polarizer.

Question 4-9: What do you observe?

Question 4-10: What has changed about the light through the plastic?

Comment: The strain partially orients the molecules and makes the plastic birefringent. From such patterns engineers can locate regions of high strain in a plastic model of a structure and then decide whether the structure must be redesigned or strengthened in certain places.

Question 4-11: In which corner of your plastic is there the greatest stress?

Activity 4-5: Polarization of Scattered Light

Sunlight is scattered while passing through the atmosphere. Light with a short wavelength is scattered more than light with a long wavelength. This is why the sky appears blue. Light scattered by 90° is strongly polarized. You can verify this on a clear day if you look through a Polaroid filter in the appropriate direction of the sky. A similar observation can be made in the laboratory by passing laser light through a tank of water that has been clouded by suspending some scattering material in it. At the front of the room there should be such a tank with a laser beam should already be passing through it.

1. From the side of the tank, at a right angle with respect to the direction of the light, examine the scattered light using a polarizer.

Question 4-12: What is the degree of polarization as a function of polarizer angle? Answer qualitatively.

